

**R : 585**

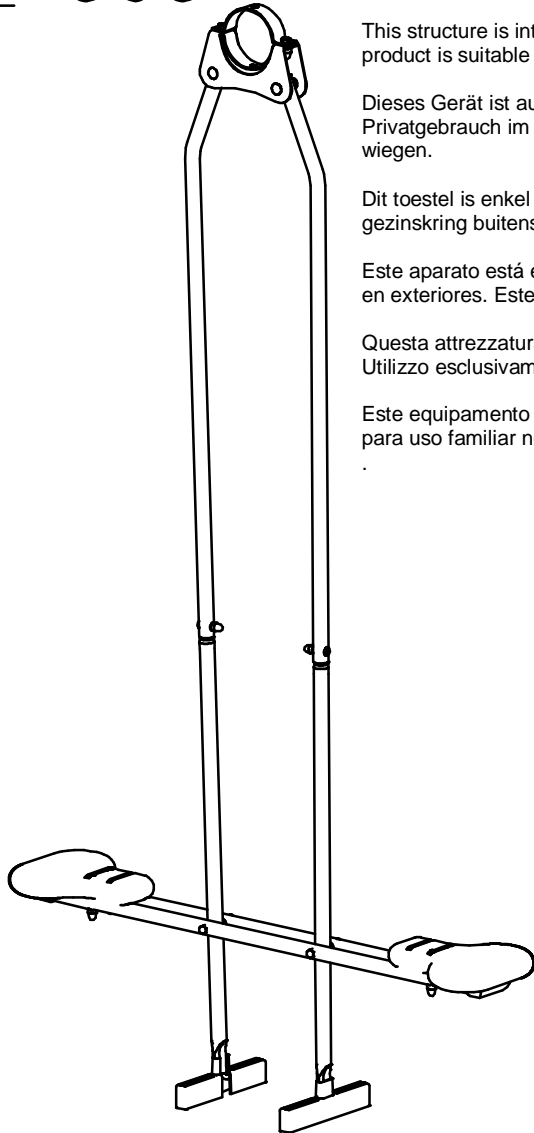

Cet agrès est destiné exclusivement à remplacer un agrès de même nature. Exclusivement à usage familial en extérieur. Ce produit convient à des enfants de 3 à 12 ans de moins de 50 kg

This structure is intended solely to replace a structure of the same type. For outdoor domestic use only. This product is suitable for children aged 3 to 12 years, up to 50kg.

Dieses Gerät ist ausschließlich als Ersatz für ein Gerät vom gleichen Typ gedacht. Ausschließlich für den Privatgebrauch im Freien. Dieses Produkt ist geeignet für Kinder von 3 bis 12 Jahren, die weniger als 50 kg wiegen.

Dit toestel is enkel bedoeld om een gelijksoortig toestel te vervangen. Uitsluitend voor gebruik in de gezinskring buitenshuis. Dit product is geschikt voor kinderen van 3 tot 12 jaar van minder dan 50 kg.

Este aparato está exclusivamente destinado a remplazar un aparato del mismo tipo. Sólo para uso doméstico en exteriores. Este producto está pensado para niños de 3 a 12 años de menos de 50kg de peso.

Questa attrezzatura è destinata esclusivamente alla sostituzione di un'altra attrezzatura dello stesso tipo. Utilizzo esclusivamente familiare, per esterni. Concepito per bambini da 3 a 12 anni e meno di 50 kg di peso.



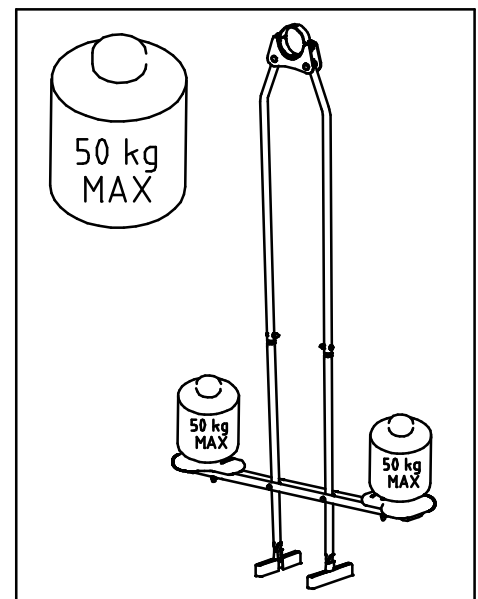



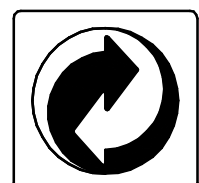
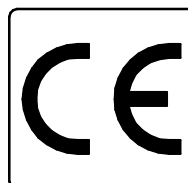
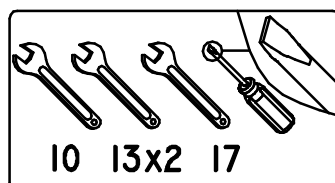
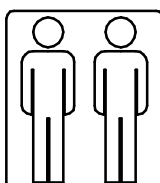
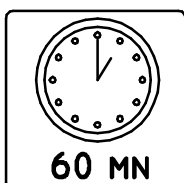

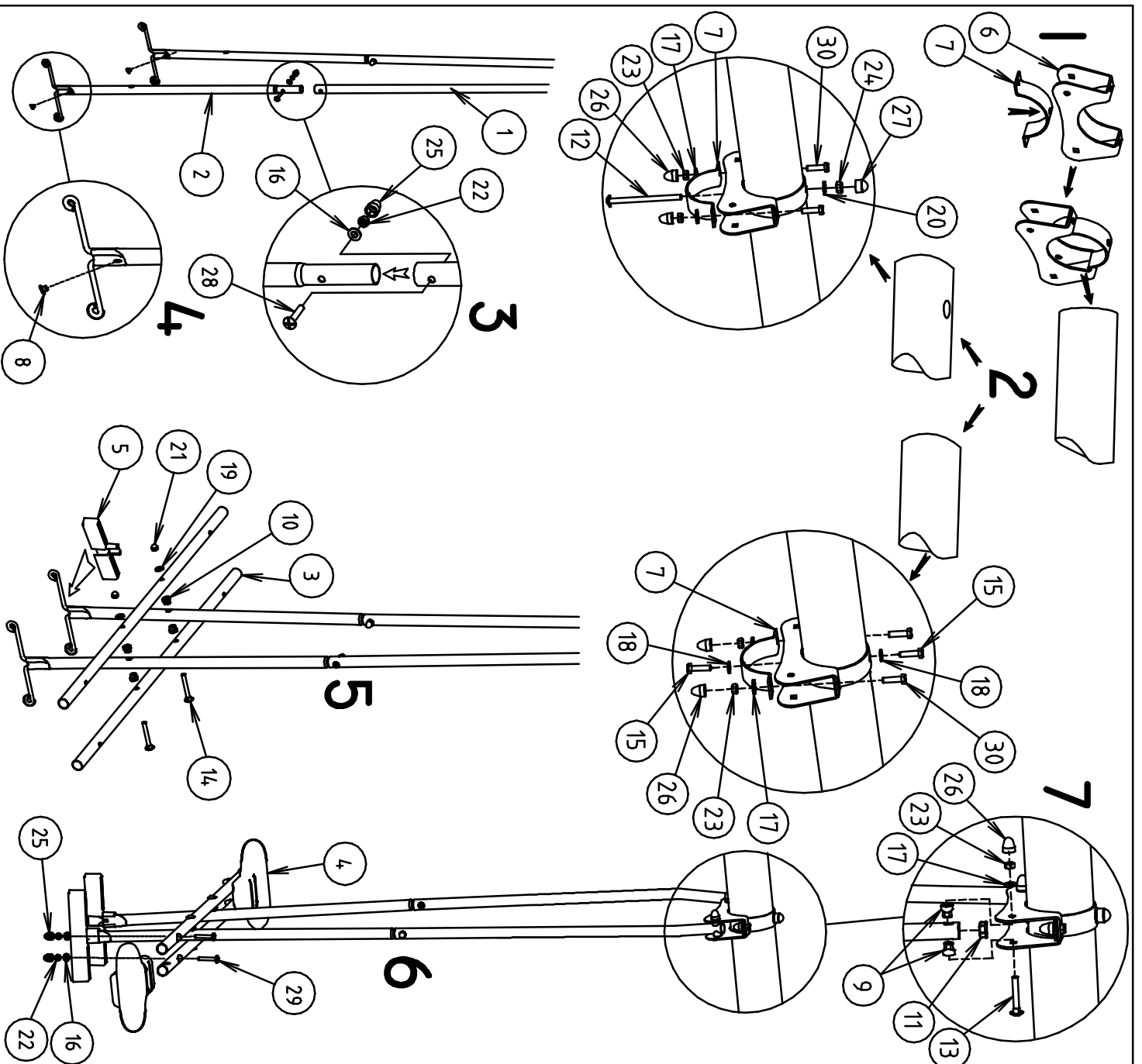

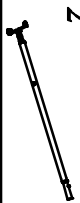
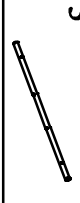

Este equipamento destinase exclusivamente a substituir um equipamento do mesmo tipo. Exclusivamente para uso familiar no exterior. Este produto convém para crianças de 3 a 12 anos com menos de 50 kg.



- Veuillez garder impérativement la notice de montage qui vous sera utile pour l'entretien de votre produit.
- It is imperative that you keep the assembly instructions, which be of use for product maintenance.
- Bewahren Sie unbedingt die Montageanleitung auf, die Sie zur Wartung und und Pflege Ihres Artikels brauchen.
- Bewaar de gebruiksaanwijzing zorgvuldig, deze zal nuttig zijn voor het onderhoud van uw product.
- Guarde imperativamente as intruções de montagem, que serão úteis para a manutenção do seu produto.
- Conservare il manuale di montaggio per le ulteriori operazioni di manutenzione.
- Conserve cuidadosamente las intrucciones de montaje, ya que le servirán para el mantenimiento de su producto.



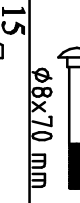

Ref., Rif., Art. Nr., Ref	Quantité, quantité, anzahl, quantity, aantal, cantidad, quantidade	Ref	Quantité, quantity, cantidad, quantidade
	15075965 x 2	16	121602 x 6
	15009765 x 2	17	121603 x 4
	15046665 x 2	18	121611 x 2
	122502 x 2	19	121609 x 2
	122562 x 2	20	121617 x 1
	15000665 x 1	21	121512 x 2
	15002065 x 2	22	121507 x 6
	122679 x 2	23	121508 x 4
	122623 x 4	24	121509 x 1
	122506 x 4	25	122591 x 6
	122536 x 2	26	122592 x 4
	121029 x 1	27	122595 x 1
	121201 x 2	28	121008 x 2
	121202 x 2	29	121014 x 4
	121306 x 2	30	121112 x 2